

Topic 17

Drive

Prof Peter YK Cheung

Dyson School of Design Engineering

URL: www.ee.ic.ac.uk/pcheung/teaching/DE1_EE/
E-mail: p.cheung@imperial.ac.uk



Electromagnetism – the foundation for motors

- ◆ **Electromagnetism** has two different facets: Electricity and magnetism
 1. a moving electric charge produces magnetic fields
 2. changing magnetic fields move electric charges
- ◆ Theories developed by: Faraday, Maxwell, Lenz
- ◆ A static distribution of **charges** produces an **electric field**
- ◆ **Charges in motion** (i.e. an electrical current) produce a **magnetic field**.

Right-hand rule:

Wrap your right hand around a conductor with thumb pointing in direction of current flow, your fingers curl in the direction of the field.

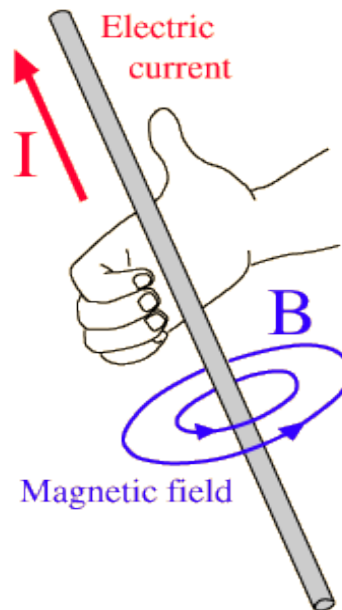

Curl your fingers in the direction of the current, your thumb points toward the north.



Electromagnets

- ◆ Arranging wire in a coil and running a current through produces a magnetic field that looks a lot like a bar of permanent magnet:
 - This is called an **electromagnet**
- ◆ Putting an iron or steel rod inside the coil makes the electromagnet stronger – the iron is magnetic, it concentrates and amplifies the magnetic field created by the current in the coil.
- ◆ Putting a permanent magnet inside, one can move the magnet back and forth depending on current direction: called a solenoid.
- ◆ A **solenoid** is a simple device illustrating how the **interaction** between the magnetic field from a permanent magnet interacts with the magnetic field produced by an electromagnet to produce force.

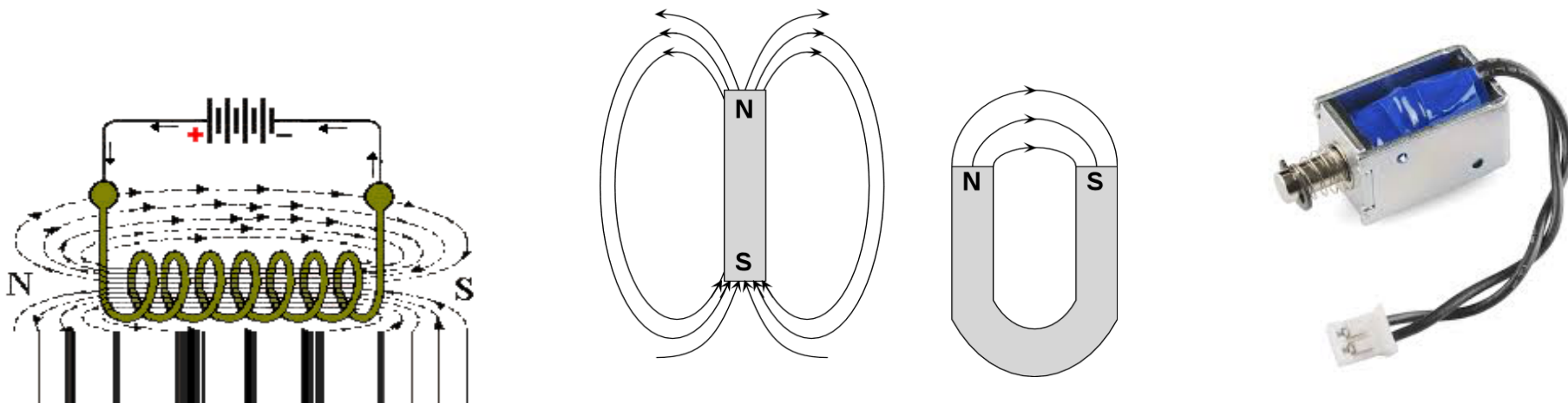

Voice Coil and Loudspeaker

- ◆ The speaker converts electrical energy into sound (kinetic) energy.
- ◆ **Alternating electrical (AC)** current causes the **voice coil** to move in relation to a permanent magnet.
- ◆ Movements in the coil are transferred to a diaphragm or cone, which create movements in air molecules and sound.
- ◆ Speaker impedance must be matched closely to the amplifier's output impedance to avoid damaging the amplifier, and to increase system efficiency.
- ◆ As speaker impedance drops, current flow increases, causing overheating of the amplifier components or distortions.

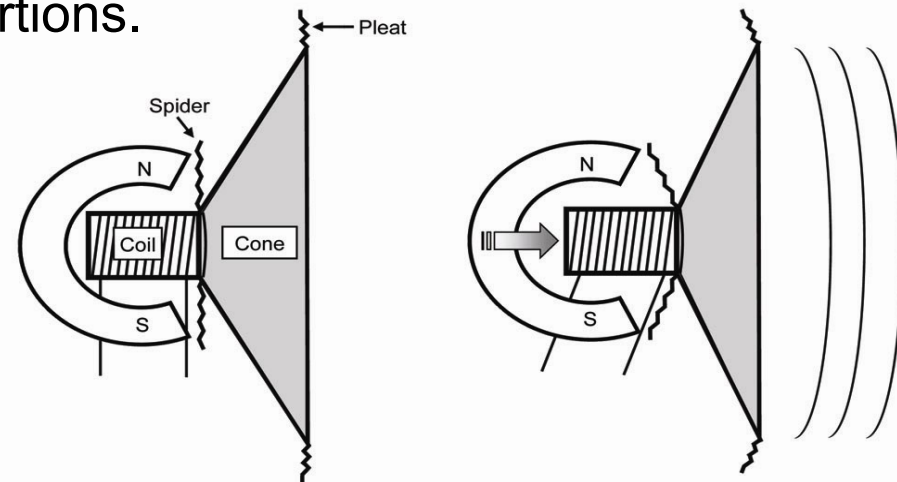

An Animation of a Speaker working (1 min)

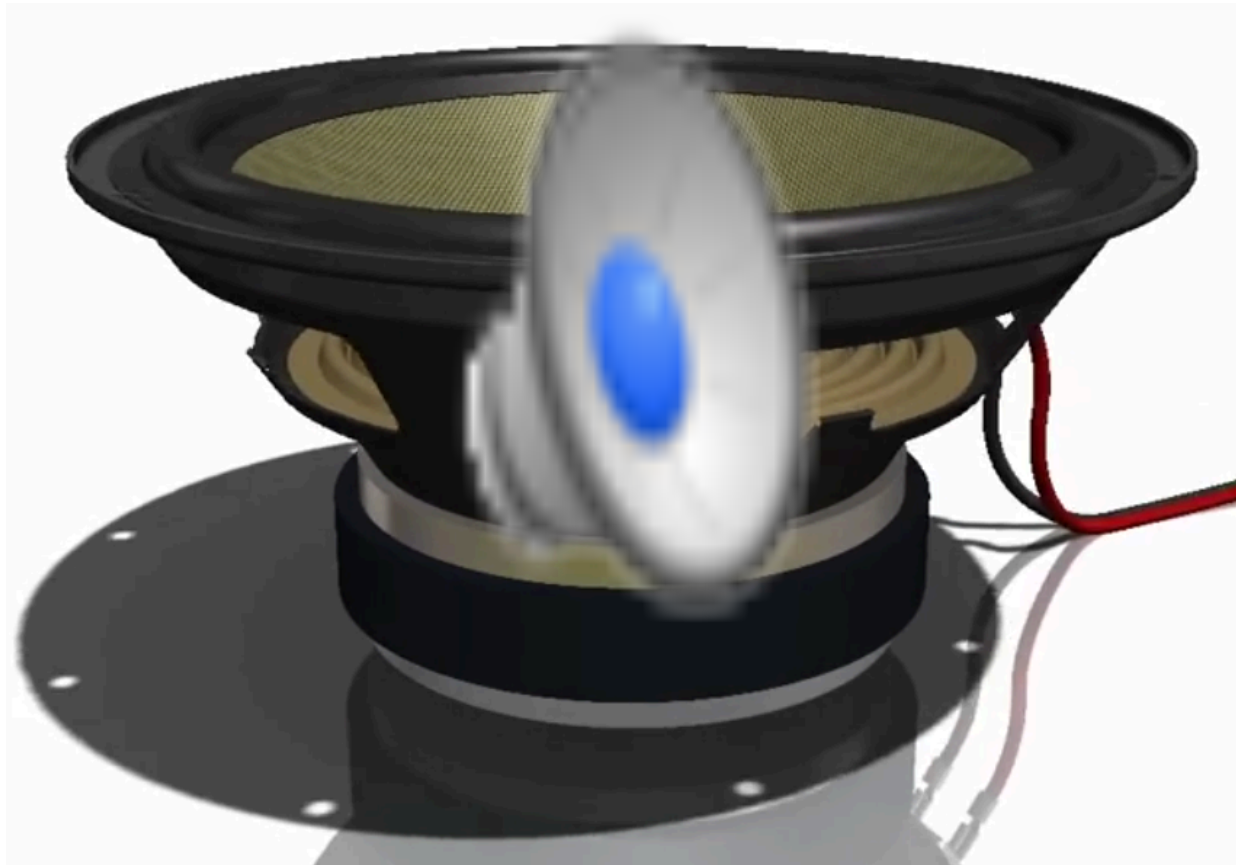

Electromagnetic Force

- ◆ The **magnetic force** on a wire is due to force acting on moving charges in the wire.
- ◆ When an electric charge moves in a magnetic field, a force **perpendicular to both** the magnetic field and to the direction of motion of the charge is produced as shown here.

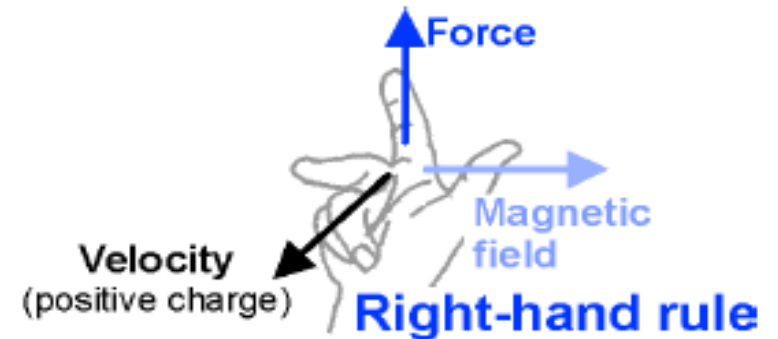
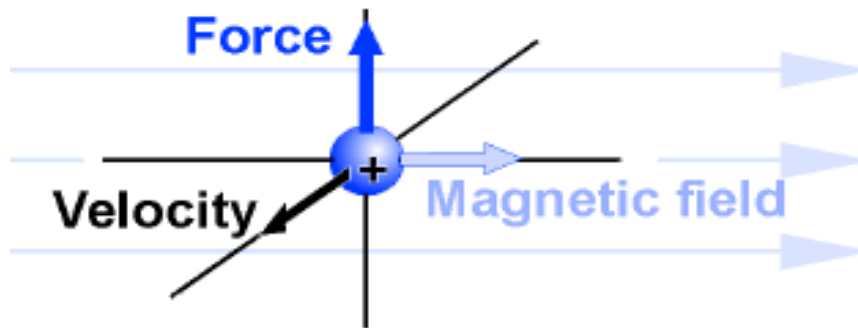

- ◆ A charge moving perpendicular to a magnetic field moves in a circular orbit.
- ◆ A charge moving at an angle to a magnetic field moves in a spiral.

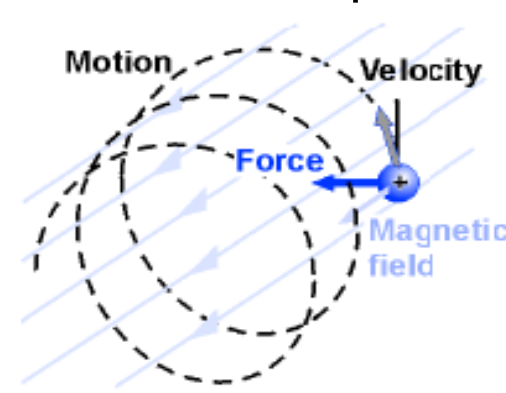
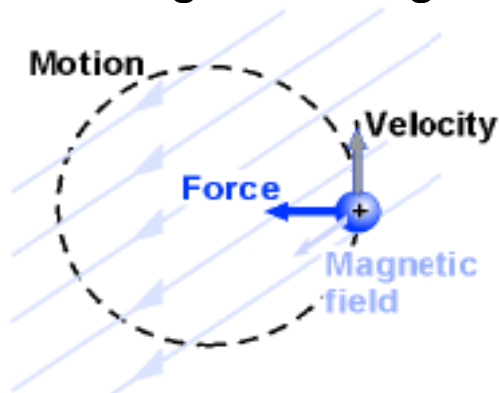

The principle of simple DC motor

- ◆ An electric motor uses electromagnets to convert electrical energy into mechanical energy.
- ◆ DC motors have three key components:
 1. A rotating element (**rotor**) with magnets.
 2. A stationary magnet that surrounds the rotor (**stator**).
 3. A **commutator** that switches the electromagnets from north to south at the right place to keep the rotor spinning.
- ◆ The magnets in the rotor and stator could be permanent magnets or electromagnets (but at least one of them have to be electromagnets).
- ◆ The rotating part of the motor, including the electromagnets, is also called the armature.

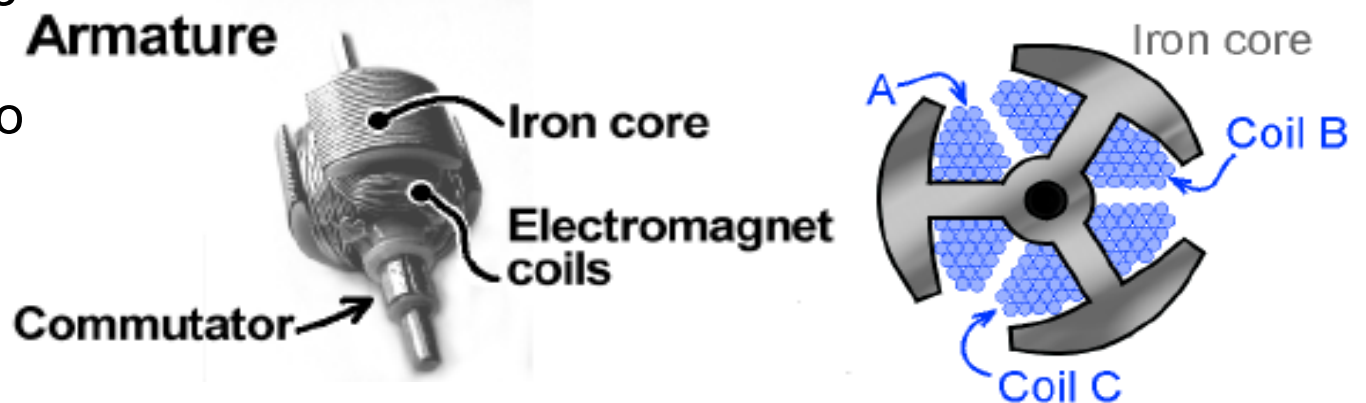

The principle of brushed DC motor

- ◆ The permanent magnets are on the outside, and they stay fixed in place.
- ◆ The wires from each of the three coils are attached to three metal plates (commutator) at the end of the armature.
- ◆ As the rotor spins, the three plates come into contact with the positive and negative brushes.
- ◆ Electric current flows through the brushes into the coils.

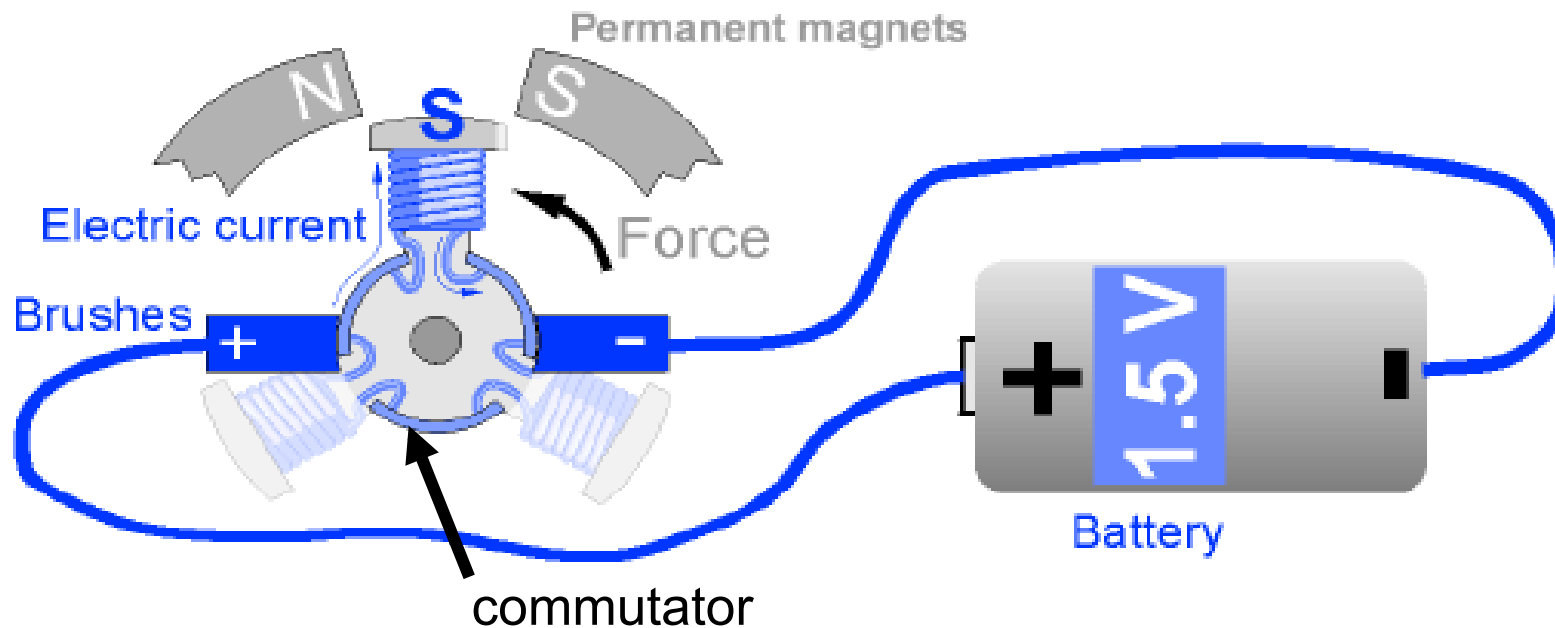

Driving a DC Motor – H-Bridge

- ◆ The DC motor needs four transistors to operate.
- ◆ In Lab 4, we used the TB6612 chip to drive the motor with four transistors.
- ◆ The combination of transistors is called an H-Bridge, due to the obvious shape. (See diagram.)
- ◆ Transistors are switched diagonally to allow DC current to flow in the motor in either direction.
- ◆ The transistors can be Pulse Width Modulated to reduce the average voltage at the motor, useful for controlling current and speed.

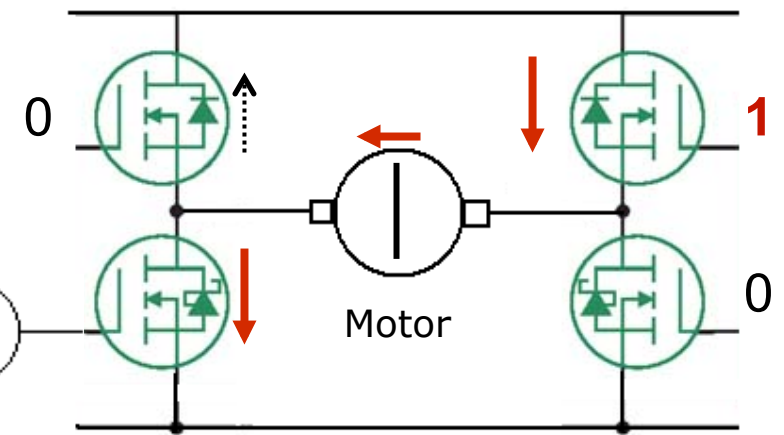
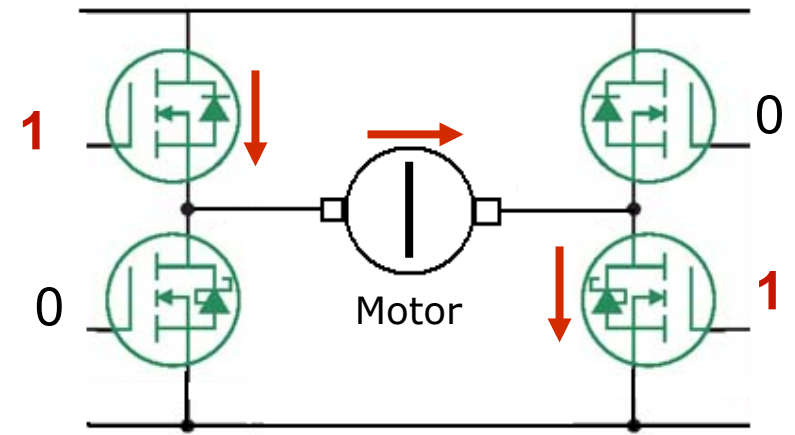
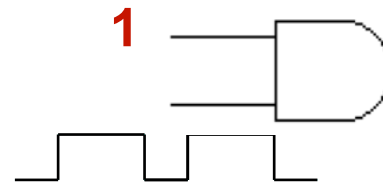
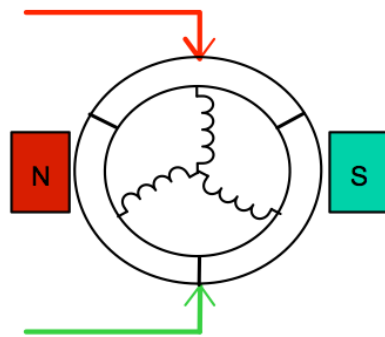

A video on how brushed DC motor works

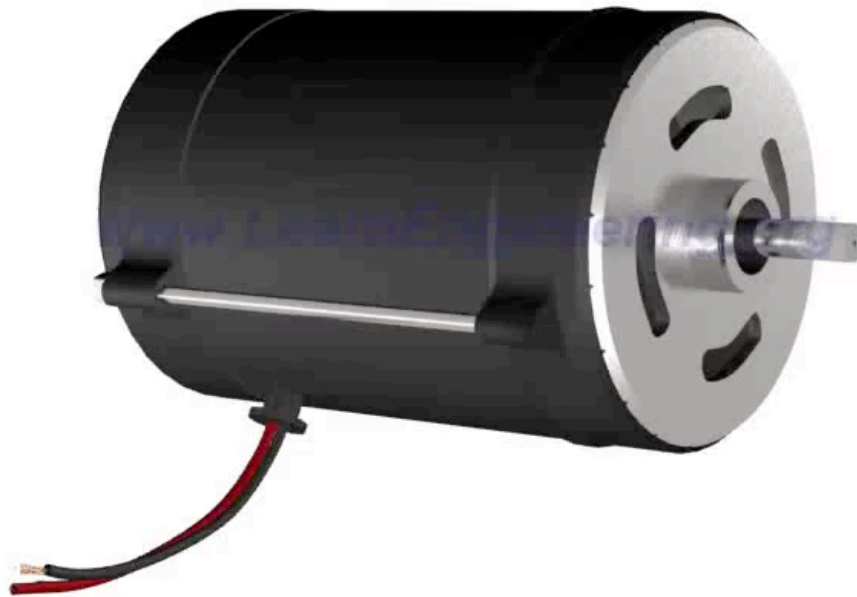

www.LearnEngineering.org

Torque, Speed, Power, Efficiency

- ◆ Speed of a DC motor drops as torque increases.
- ◆ Here is the relationships of various parameters: speed, current, power and efficiency, as a function of torque.

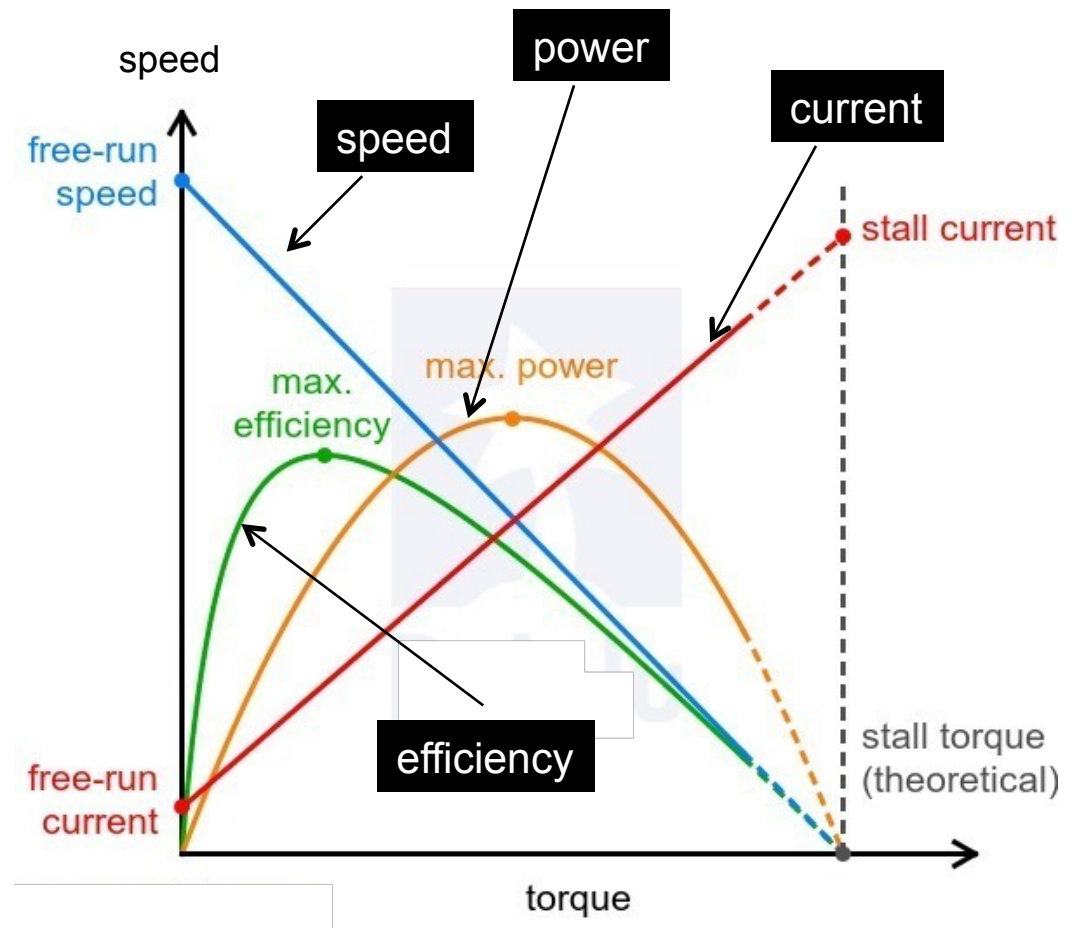

Principle of Servo Motor

- ◆ Servo motors are constructed out of basic DC motors, running in a close loop, by adding:
 - some gear reduction
 - a position sensor for the motor shaft
 - an electronic circuit that controls the motor's operation
- ◆ The basic hobby servo has a 180:1 gear ratio. The motor is typically small.
- ◆ Typically, a potentiometer (variable resistor) measures the position of the output shaft at all times so the controller can accurately place and maintain its setting.

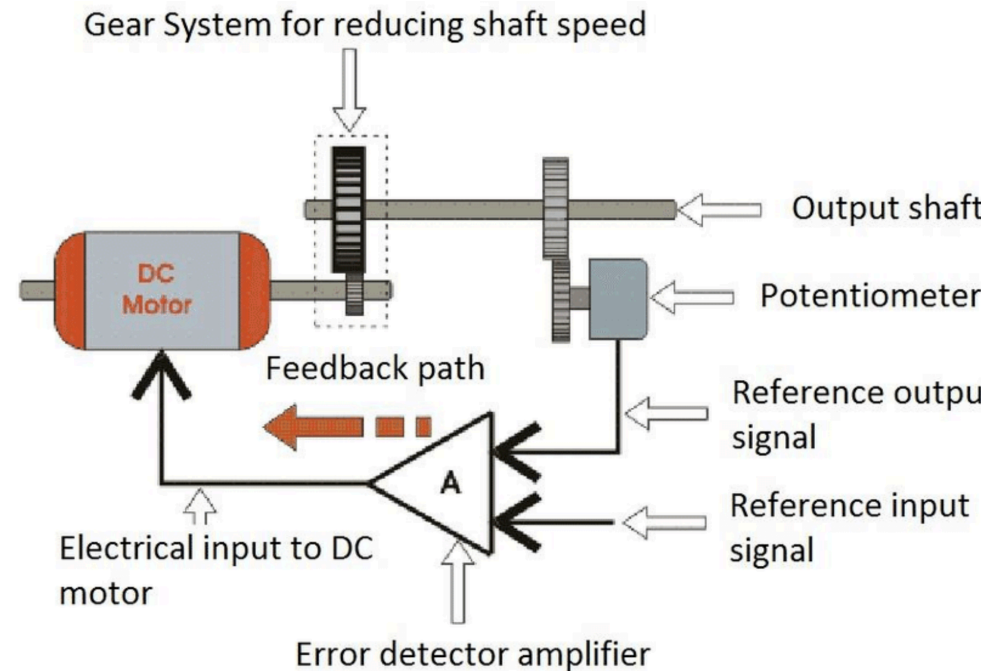

PWM = Orange (⏏)
Vcc = Red (+)
Ground = Brown (-)

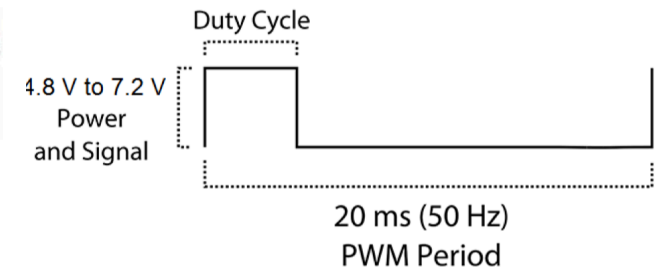

Servo Motor Control

- ◆ An external controller (such as the ESP32) tells the servo where to go with a signal known as pulse proportional modulation (PPM) or pulse code modulation (which is often confused with pulse width modulation, PWM).
- ◆ PPM uses 1 to 2ms out of a 20ms time period to encode its information.
- ◆ A control wire communicates the desired angular movement. The angle is determined by the duration of the pulse applied to the control wire.
- ◆ The servo expects to see a pulse every 20 milliseconds (.02 seconds). The length of the pulse will determine how far the motor turns. A 1.5 millisecond pulse will make the motor turn to the 90 degree position (often called the neutral position).
- ◆ If the pulse is shorter than 1.5 ms, then the motor will turn the shaft to closer to 0 degrees. If the pulse is longer than 1.5ms, the shaft turns closer to 180 degrees.

Servo Motor PWM signal

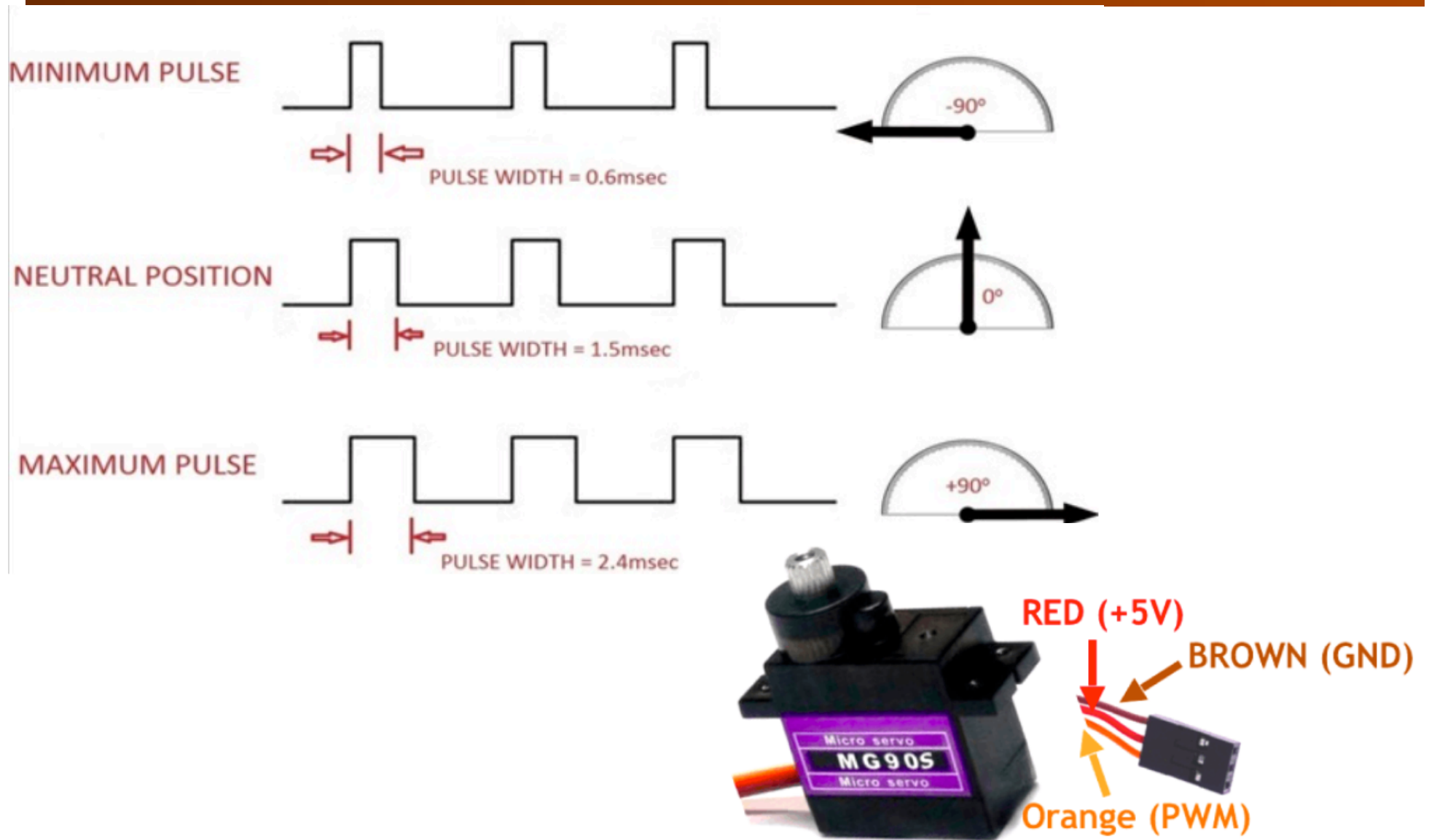

Principle of a stepper motor – full steps

- ◆ The rotor of a permanent magnet in stepper motor consists of permanent magnets and the stator has two pairs of windings.
- ◆ Just as the rotor aligns with one of the stator poles, the second phase is energized.
- ◆ The two phases alternate on and off and also reverse polarity.
- ◆ There are four FULL steps. One phase lags the other phase by one step. This is equivalent to one fourth of an electrical cycle or 90° .
- ◆ Electronic circuits are used to switch supply voltages to the appropriate windings in the stator to advance each step. (See animation.)

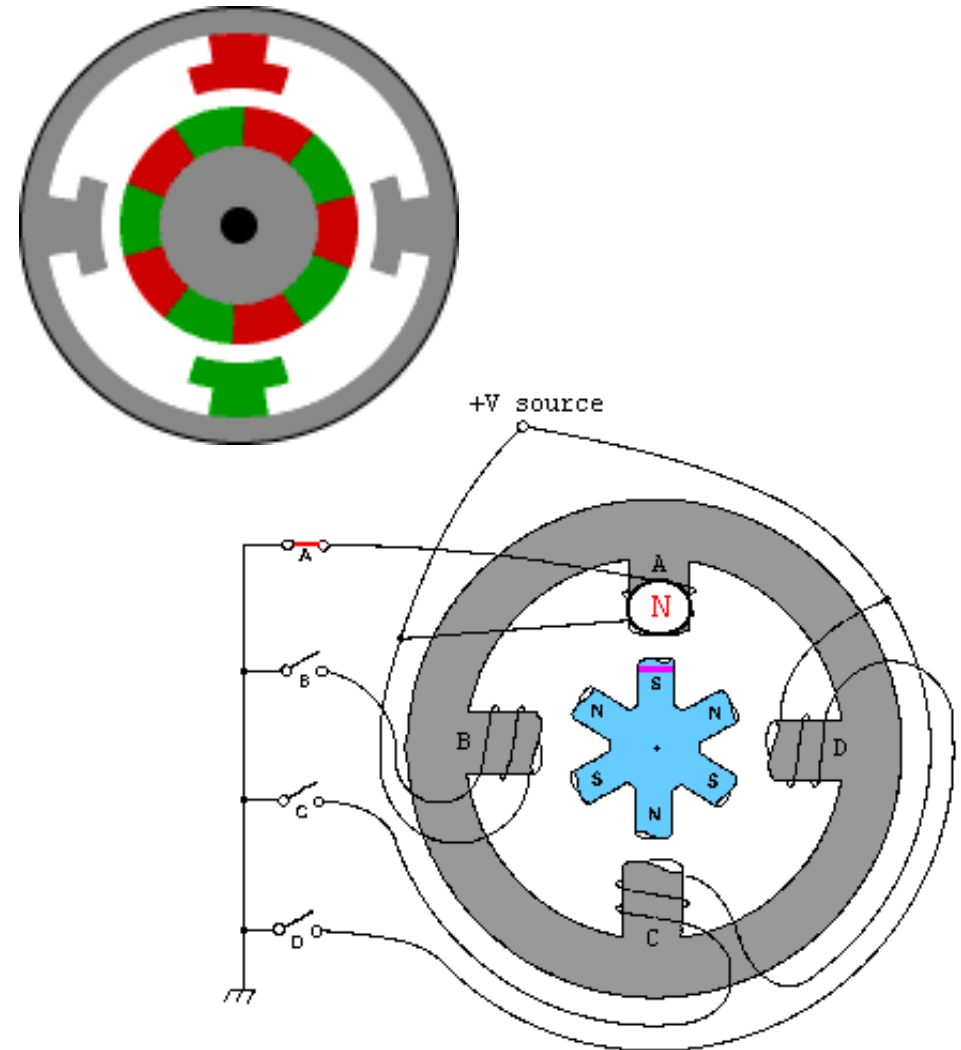

Principle of a stepper motor – half steps

- ◆ By energizing two windings some of the time, we get a half-step stepper motor.
- ◆ The commutation sequence for a half-step stepper motor has eight steps instead of four.
- ◆ The main difference is that the second phase is turned on before the first phase is turned off. Thus, sometimes both phases are energized at the same time.
- ◆ During the half-steps the rotor is held in between the two full-step positions.
- ◆ A half-step motor has twice the resolution of a full step motor. It is very popular for this reason.
- ◆ Step resolution can also be increased with more poles in the stator, resulting in more steps.
- ◆ Stepper motors is normally run open loop without sensors or feedback.
- ◆ Good for applications such as printers.

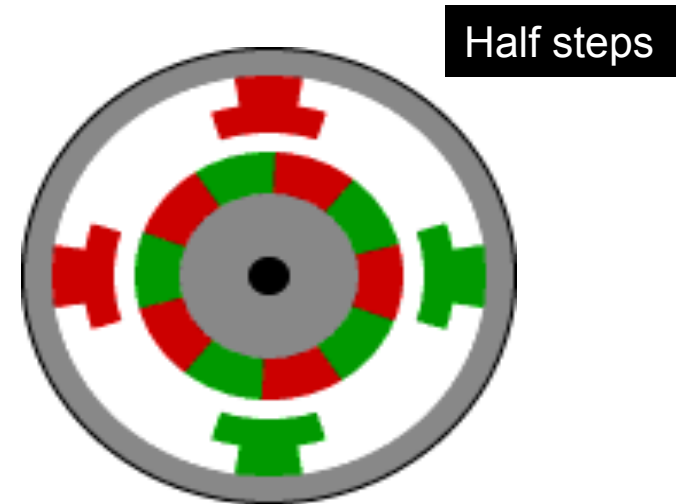
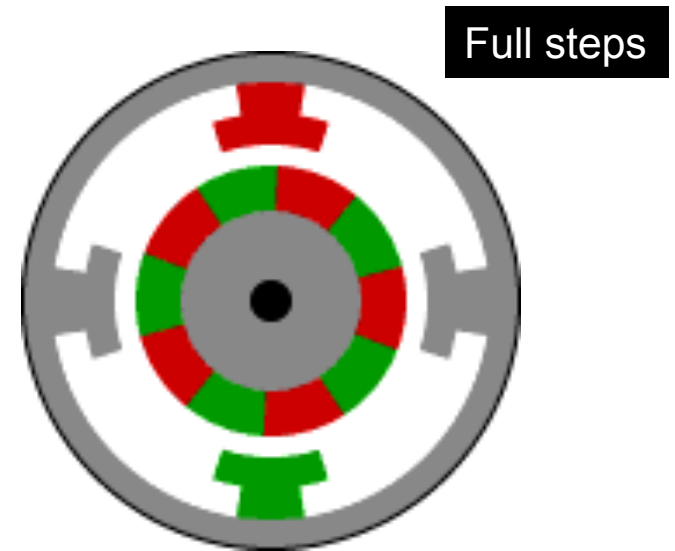

A video on comparing stepper and servo motors

